

## TENTA WH



TENTA 900 XGWH  
Cod. **02189005** EAN **8422248093729**

- Touch Control Panel** with digital display, automatic shut-down timer and cleaning filters indicator
- AUTO connectivity with automatic control from the CATA hob**
- 6 extraction levels, 5 + 1 **TURBO**
- Extraction power (according to UNE/EN 61591): **765,3m³/h** - 245m³/h
- Maximum air flow (free outlet): **1200m³/h**
- Sound power (Reg.(EU) n°65/2014): 46dB(A)**, maximum: 63dB(A)
- BRUSHLESS motor. Ultra silent. Maximum energy consumption **135W**
- High-efficiency lighting by intensity-adjustable two-tone warm / natural LED STRIP**
- Easy-to-install system
- Dishwasher-washable filters
- Glass visor furniture protection and **opening for intensive use**
- White glass finishing
- Max. Pressure: 357 Pa
- 150/125 mm outlet diameter
- Energy Class: A+**

► **Accessories (not included)**

Active charcoal filter .....Cod. 02859399 / EAN 8422248086943 .....  
Check valve .....Cod. 02832008 / EAN 8422248086837 .....

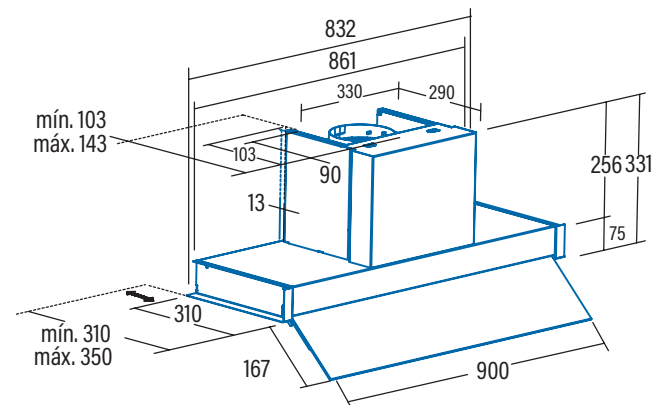

|   |                      |
|---|----------------------|
| <b>Code</b>   | <b>02189005</b>      |
| <b>EAN</b>  | <b>8422248093729</b> |
| <b>Model</b>  | <b>TENTA 90 GWH</b>  |
| <b>Type</b>   | Integrated           |
| <b>Product fiche according to directives EU65/2014 - EN61591, EN60704-2-13, EN50564</b> |                      |
| AEC (Annual Energy consumption) (kWh/annum)   | 24,7                 |
| EEL class (Energy Efficiency Class)   | A+                   |
| FDE (Fluid Dynamic Efficiency)  | 37,5                 |
| FDE class (Fluid Dynamic Efficiency Class)  | A                    |
| LE (Lighting Efficiency) (lux/W)  | 23,7                 |
| LE class (Lighting Efficiency Class)  | B                    |
| GFE (Grease Filtering Efficiency)   | 62,7                 |
| GFE Class (Grease Filtering Efficiency class)   | E                    |
| Air flow at minimum speed (m³/h)  | 245                  |
| Air flow at maximum speed (m³/h)  | 509,4                |
| Air flow at intensive speed (TURBO) (m³/h)  | 765,3                |
| Sound Power Level at minimum speed (dB)   | 46                   |
| Sound Power Level at maximum speed (dB)   | 63                   |
| Sound Power Level at intensive speed (TURBO) (dB)                                       | 67                   |
| Po (Power Consumption in off mode) (W)  | 0,49                 |
| Ps (Power Consumption in standby) (W)   | 0                    |
| <b>Integration directive EU 66/2014</b>   |                      |
| f (Time Increase Factor)  | 0,7                  |
| EEL (Energy Efficiency Index)   | 40,3                 |
| QBEP (Flow Rate at Best Efficiency Point) (m³/h)  | 346,6                |
| PBEP (Static Pressure Difference at Best Efficiency Point) (Pa)                         | 298                  |
| WBEP (Electric Power Input at Best Efficiency Point) (W)                                | 76,6                 |
| WL (Nominal Power Consumption of Lighting system) (W)                                   | 7                    |
| EMIDDLE (Average Illumination of Lighting system on Cooking surface) (lux)              | 166                  |
| <b>External Dimensions</b>  |                      |
| Width (mm)  | 900                  |
| Depth (mm)  | 310-350              |
| Total max height (mm)   | 331                  |
| Total min height (mm)   | 331                  |
| Outlet Diameter (mm)  | 150                  |
| <b>Characteristics</b>  |                      |
| Motor   | BT4DC                |
| Extraction Levels   | 5+1                  |
| Motor Maximum Power Consumption   | 135                  |
| Maximum Pressure  | 357                  |
| Intensive Speed (TURBO) Pressure  | 365                  |
| Control Type  | TCD6i                |
| Automatic shut-down timer   | √                    |
| Electronic Filter Saturation Indicator  | √                    |
| Filter Type   | Metallic             |
| Anti-grease Filter Number   | 3                    |
| Inner Shield  | -                    |
| <b>Lighting</b>   |                      |
| Light Type  | SSLED                |
| Adjustable Intensity Lighting   | √                    |
| N° of Lamps   | 1                    |
| <b>Installation</b>   |                      |
| Minimum height distance to a electric worktop hob (mm)                                  | 550                  |
| Minimum height distance to a gas worktop hob (mm)                                       | 650                  |
| Installation with Outlet tube to the exterior / Recirculating                           | BOTH                 |
| Easy Installation System  | √                    |
| <b>Electric Connection</b>  |                      |
| Total Rush Power (W)  | 146                  |
| Rated Voltage (V)   | 220-240              |
| Network Frequency (Hz)  | 50                   |
| Electrical Insulation Class   | CLASS I              |
| Plug  | -                    |
| <b>Accessories</b>  |                      |
| Upper Decorative tube Extension   | -                    |
| White Decorative Tube   | -                    |
| Black Decorative Tube   | -                    |
| Island Tube Enhancer  | -                    |
| Check Valve   | 02832008             |
| MAX PRO Metal Filter  | -                    |
| Metal Filter  | 02811000             |
| DUAL Filter (metal + active charcoal)   | 02811003             |
| Active Charcoal Filter  | 02859399             |
| Noiseless Flexible Duct   | 02893002             |