



V-700 X

Cod. **02085600** EAN **8422248087285**



Mechanical control panel

- 3 extraction levels
- Extraction power (according to UNE/EN 61591): **420m³/h** - 210m³/h
- Maximum airflow free outlet: **750m³/h**
- **Sound power (Reg. (EU) n°65/2014): 53dB(A)**, maximum: 65dB(A)
- 1 Motor. Extra silent. Maximum energy consumption **95W**
- **High efficiency LED E-14 lighting**
- Easy-to-install system
- Dishwasher-washable filters
- Finished in stainless steel
- Max. pressure 200 Pa
- 150/125 mm outlet diameter
- Energy Class: C

Accessories (not included)

Active charcoal filter
Top tube

Cod. 02859394 / EAN 8422248038782
Cod. 028663304 / EAN 8422248106788

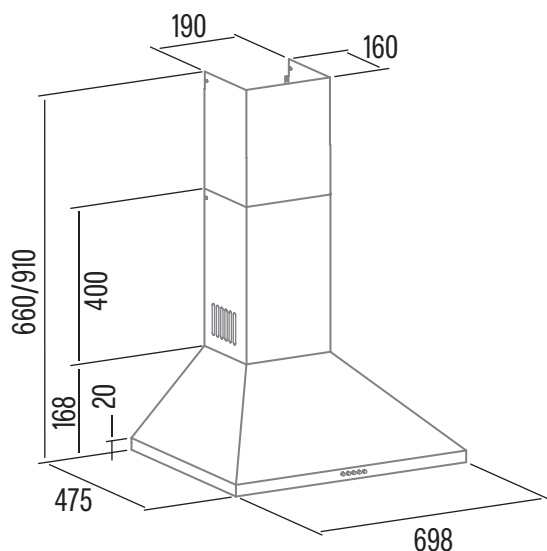

Code	02085600
EAN	8422248087285
Model	V-700 X
Type	Chimney
Product fiche according to directives EU65/2014 - EN61591, EN60704-2-13, EN50564	
AEC (Annual Energy consumption) (kWh/annum)	53,7
EEL class (Energy Efficiency Class)	C
FDE (Fluid Dynamic Efficiency)	10,3
FDE class (Fluid Dynamic Efficiency Class)	E
LE (Lighting Efficiency) (lux/W)	8,4
LE class (Lighting Efficiency Class)	E
GFE (Grease Filtering Efficiency)	71,4
GFE Class (Grease Filtering Efficiency class)	D
Air flow at minimum speed (m ³ /h)	210
Air flow at maximum speed (m ³ /h)	420
Air flow at intensive speed (TURBO) (m ³ /h)	-
Sound Power Level at minimum speed (dB)	53
Sound Power Level at maximum speed (dB)	65
Sound Power Level at intensive speed (TURBO) (dB)	-
Po (Power Consumption in off mode) (W)	0
Ps (Power Consumption in standby) (W)	0
Integration directive EU 66/2014	
f (Time Increase Factor)	1,6
EEL (Energy Efficiency Index)	84,4
QBEP (Flow Rate at Best Efficiency Point) (m ³ /h)	220
PBEP (Static Pressure Difference at Best Efficiency Point) (Pa)	130
WBEP (Electric Power Input at Best Efficiency Point) (W)	76,9
WL (Nominal Power Consumption of Lighting system) (W)	11
EMIDDLE (Average Illumination of Lighting system on Cooking surface) (lux)	208,8
External Dimensions	
Width (mm)	700
Depth (mm)	475
Total max height(mm)	910
Total min height(mm)	610
Outlet Diameter (mm)	150/125
Characteristics	
Motor	K7 PLUS
Extraction Levels	3
Motor Maximum Power Consumption	95
Maximum Pressure	200
Intensive Speed (TURBO) Pressure	-
Control Type	Mechanic
Automatic shut-down timer	-
Electronic Filter Saturation Indicator	-
Filter Type	Metallic
Anti-grease Filter Number	2
Inner Shield	-
Lighting	
Light Type	LED E-14
Adjustable Intensity Lighting	-
N° of Lamps	2
Installation	
Minimum height distance to a electric worktop hob (mm)	650
Minimum height distance to a gas worktop hob (mm)	650
Installation with Outlet tube to the exterior / Recirculating	BOTH
Easy Installation System	√
Electric Connection	
Total Rush Power (W)	106
Rated Voltage (V)	220-240
Network Frequency (Hz)	50
Electrical Insulation Class	CLASS II
Plug	EU - 2 pins
Accessories	
Upper Decorative tube Extension	02862302
White Decorative Tube	-
Black Decorative Tube	-
Island Tube Enhancer	-
Check Valve	02832004
MAX PRO Metal Filter	02800917
Metal Filter	02800905*
DUAL Filter (metal + active charcoal)	02800918
Active Charcoal Filter	02859394
Noiseless Flexible Duct	02893002