



## VALTO WH



VALTO 700 XGWH  
Cod. **02078003** EAN **8422248094078**

- ❑ **Touch Control Panel** with digital display, automatic shut-down timer and cleaning filters indicator
- ❑ 6 extraction levels, **5 + 1 TURBO**
- ❑ Extraction power (according to UNE/EN 61591): **575m³/h - 170m³/h**
- ❑ Maximum air flow (free outlet): **900m³/h**
- ❑ **Sound power (Reg.(EU) n°65/2014): 44dB(A)**, maximum: 61dB(A)
- ❑ BT3 motor. Extra silent. Maximum energy consumption **110W**
- ❑ **High efficiency Strip Led lighting, adjustable intensity**
- ❑ Easy-to-install system
- ❑ Dishwasher-washable filters
- ❑ Finished in Stainless steel
- ❑ Max. Pressure: 470 Pa
- ❑ 150/125 mm outlet diameter
- ❑ **Energy Class: A+**

► **Accessories (not included)**

Active charcoal filter .....Cod. 02859394 / EAN 8422248038782.....  
Check valve .....Cod. 02832004 / EAN 8422248480499.....

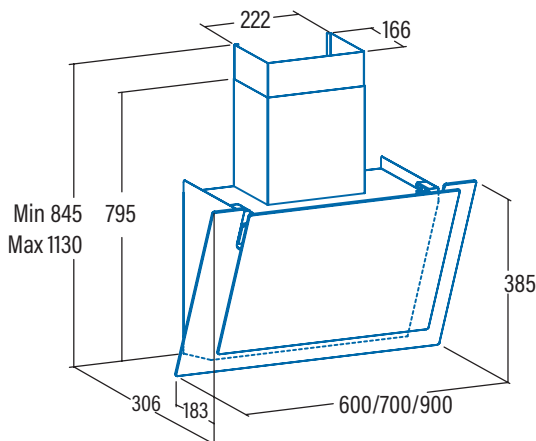

<b>Code</b>	<b>02078003</b>
<b>EAN</b>	<b>8422248094078</b>
<b>Model</b>	<b>VALTO 700 XGWH</b>
<b>Type</b>	Vertical
<b>Product fiche according to directives EU65/2014 - EN61591, EN60704-2-13, EN50564</b>	
AEC (Annual Energy consumption) (kWh/annum)	23,1
EEl class (Energy Efficiency Class)	A+
FDE (Fluid Dynamic Efficiency)	30,7
FDE class (Fluid Dynamic Efficiency Class)	A
LE (Lighting Efficiency) (lux/W)	22,6
LE class (Lighting Efficiency Class)	B
GFE (Grease Filtering Efficiency)	60,9
GFE Class (Grease Filtering Efficiency class)	E
Air flow at minimum speed (m³/h)	170
Air flow at maximum speed (m³/h)	385
Air flow at intensive speed (TURBO) (m³/h)	575
Sound Power Level at minimum speed (dB)	44
Sound Power Level at maximum speed (dB)	61
Sound Power Level at intensive speed (TURBO) (dB)	69
Po (Power Consumption in off mode) (W)	0,4
Ps (Power Consumption in standby) (W)	0
<b>Integration directive EU 66/2014</b>	
f (Time Increase Factor)	0,9
EEl (Energy Efficiency Index)	44,7
QBEP (Flow Rate at Best Efficiency Point) (m³/h)	243,6
PBEP (Static Pressure Difference at Best Efficiency Point) (Pa)	284
WBEP (Electric Power Input at Best Efficiency Point) (W)	62,6
WL (Nominal Power Consumption of Lighting system) (W)	3,5
EMIDDLE (Average Illumination of Lighting system on Cooking surface) (lux)	22,6
<b>External Dimensions</b>	
Width (mm)	700
Depth (mm)	306
Total max height (mm)	1120
Total min height (mm)	820
Outlet Diameter (mm)	150/125
<b>Characteristics</b>	
Motor	TIDC
Extraction Levels	5 + 1
Motor Maximum Power Consumption	110
Maximum Pressure	250
Intensive Speed (TURBO) Pressure	315
Control Type	TCD6i
Automatic shut-down timer	√
Electronic Filter Saturation Indicator	√
Filter Type	Metallic
Anti-grease Filter Number	1
Inner Shield	-
<b>Lighting</b>	
Light Type	SS Led
Adjustable Intensity Lighting	√
N° of Lamps	1
<b>Installation</b>	
Minimum height distance to a electric worktop hob (mm)	400
Minimum height distance to a gas worktop hob (mm)	650
Installation with Outlet tube to the exterior / Recirculating	BOTH
Easy Installation System	√
<b>Electric Connection</b>	
Total Rush Power (W)	113
Rated Voltage (V)	220-240
Network Frequency (Hz)	50
Electrical Insulation Class	CLASS I
Plug	-
<b>Accessories</b>	
Upper Decorative tube Extension	-
White Decorative Tube	-
Black Decorative Tube	-
Island Tube Enhancer	-
Check Valve	02832004
MAX PRO Metal Filter	-
Metal Filter	02800930
DUAL Filter (metal + active charcoal)	02800922
Active Charcoal Filter	02859394
Noiseless Flexible Duct	02893002