

CORONA X 100

CORONA X 100

Cod. **02180308** EAN **8422248198547**

- Electronic Control Panel** with digital display automatic shut-down timer
- 4 extraction levels, 3 + 1 **TURBO**
- Extraction power (according to UNE/EN 61591): **850m³/h - 340m³/h**
- Sound power (Reg.(EU) n°65/2014): 50dB(A)**, maximum: 65dB(A)
- BT3 motor. Ultra silent. Maximum energy consumption **283W**
- High efficiency strip led lighting**
- Easy-to-install system
- Fully stainless steel washable dishwasher filters
- Glass Visor**
- Stainless steel finishing
- Max. Pressure: 470 Pa
- 150/125 mm outlet diameter
- Energy Class: A**

► **Accessories (not included)**

Active charcoal filter	Cod. 02859398 / EAN 8422248075497
Check valve	Cod. 02832004 / EAN 8422248480499
Duct cover	Cod. 02861306 / EAN 8422248109949

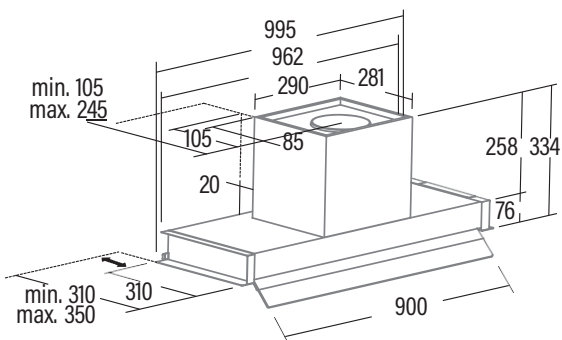

Code	02180308
EAN	8422248198547
Model	CORONA X 100
Type	Integrated
Product fiche according to directives EU65/2014 - EN61591, EN60704-2-13, EN50564	
AEC (Annual Energy consumption) (kWh/annum)	51,9
EI class (Energy Efficiency Class)	A
FDE (Fluid Dynamic Efficiency)	30,6
FDE class (Fluid Dynamic Efficiency Class)	A
LE (Lighting Efficiency) (lux/W)	22,3
LE class (Lighting Efficiency Class)	B
GFE (Grease Filtering Efficiency)	84,27
GFE Class (Grease Filtering Efficiency class)	C
Air flow at minimum speed (m3/h)	340
Air flow at maximum speed (m3/h)	600
Air flow at intensive speed (TURBO) (m3/h)	850
Sound Power Level at minimum speed (dB)	50
Sound Power Level at maximum speed (dB)	65
Sound Power Level at intensive speed (TURBO) (dB)	67
Po (Power Consumption in off mode) (W)	0,26
Ps (Power Consumption in standby) (W)	0
Integration directive EU 66/2014	
f (Time Increase Factor)	0,9
EI (Energy Efficiency Index)	53,3
QBEP (Flow Rate at Best Efficiency Point) (m3/h)	416,9
PBEP (Static Pressure Difference at Best Efficiency Point) (Pa)	411
WBEP (Electric Power Input at Best Efficiency Point) (W)	155,7
WL (Nominal Power Consumption of Lighting system) (W)	3
EMIDDLE (Average Illumination of Lighting system on Cooking surface) (lux)	67
External Dimensions	
Width (mm)	995
Depth (mm)	310-350
Total max height(mm)	334
Total min height(mm)	334
Outlet Diameter (mm)	150/125
Characteristics	
Motor	BT3
Extraction Levels	3 + 1
Motor Maximum Power Consumption	280
Maximum Pressure	450
Intensive Speed (TURBO) Pressure	470
Control Type	VL4i
Automatic shut-down timer	√
Electronic Filter Saturation Indicator	-
Filter Type	Metallic
Anti-grease Filter Number	2
Inner Shield	-
Lighting	
Light Type	SS Led
Adjustable Intensity Lighting	-
N° of Lamps	1
Installation	
Minimum height distance to a electric worktop hob (mm)	550
Minimum height distance to a gas worktop hob (mm)	650
Installation with Outlet tube to the exterior / Recirculating	BOTH
Easy Installation System	√
Electric Connection	
Total Rush Power (W)	283
Rated Voltage (V)	220-240
Network Frequency (Hz)	50
Electrical Insulation Class	CLASS II
Plug	-
Accessories	
Upper Decorative tube Extension	02861306
White Decorative Tube	-
Black Decorative Tube	-
Island Tube Enhancer	-
Check Valve	02832004
MAX PRO Metal Filter	-
Metal Filter	02800205
DUAL Filter (metal + active charcoal)	-
Active Charcoal Filter	02859398
Noiseless Flexible Duct	02893002